

Setting Instructions

Optical Anti-Collision Device Type CPV1038

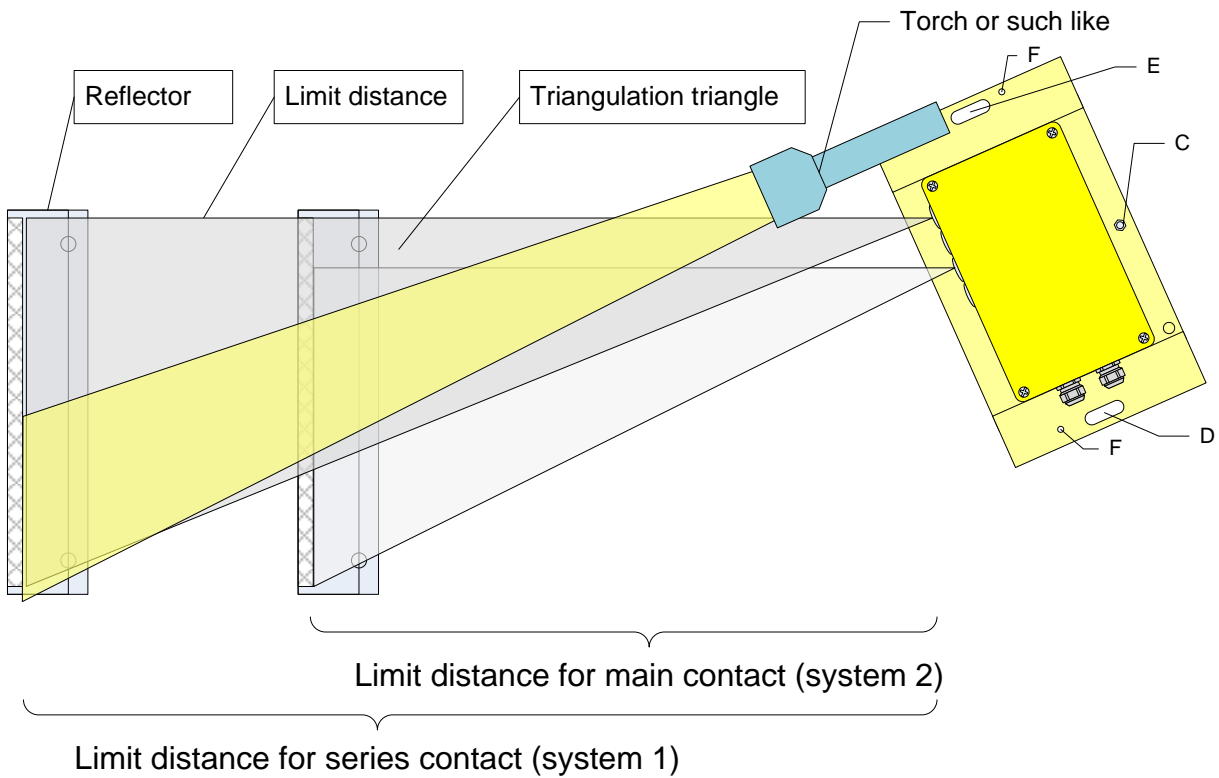

Installation possibilities:

Alignment of the triangulation triangle,

- horizontal, angle to the left (see sketch)
- horizontal, angle to the right

F = fastening with dowel pins

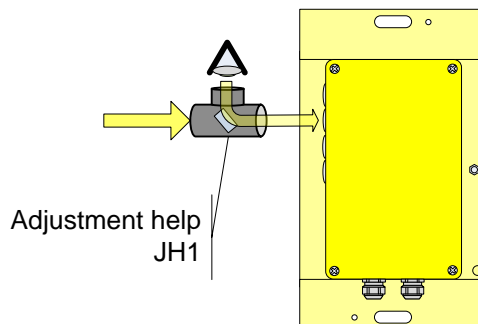

Reflector image – Example:

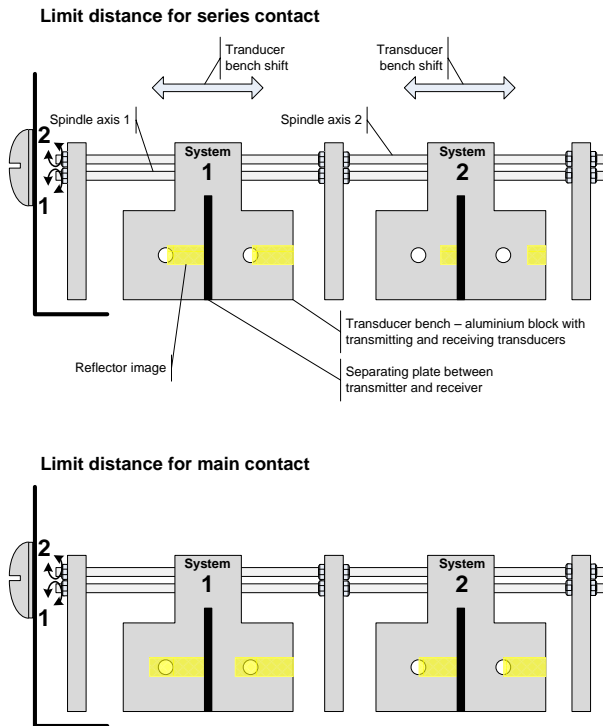

Example: Reflector image on the transducer bench at limit distance for horizontal triangulation triangles formed to the left.

Note: Depending on the limit clearance (and reflector height) the reflector image is more or less large in comparison to the transducer boreholes! The degree to which the transducer boreholes are covered also depends on the distance. The brightness of the reflector image does not depend on the utilized lamp alone but also on the position of the lamp to the optical elements.

Installation Example:

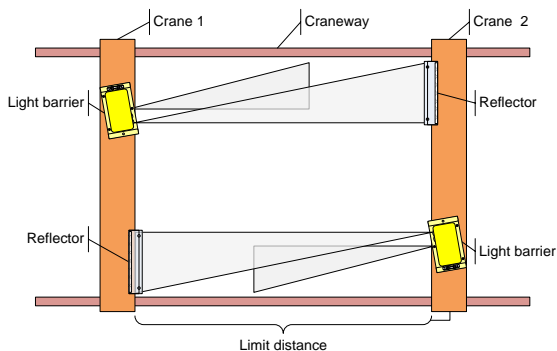

Electrical Connection:

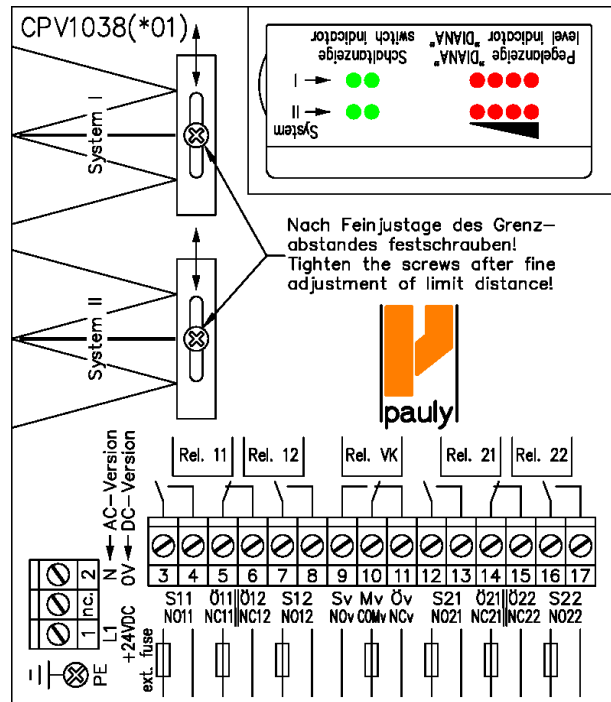

	Cl. 1	Cl. 2	PE
230VAC:	L	N	PE
115VAC:	L	N	PE
42...48VAC:	L	N	PE
24VDC:	+	0V	-/-

Mounting the Reflector:

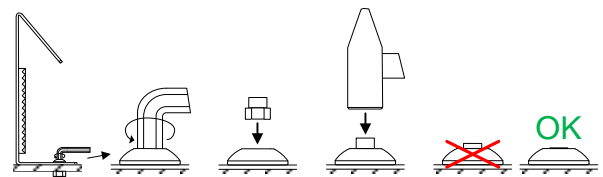

Note on safety:



Please refer to the manual (E_52692) for assembly, connecting and adjustment instructions of the light barrier and the corresponding accessories.

